



PRODUCTIVITY POINTERS | Overhead Cranes

Here's how Mobil SHC can help make the machinery in your overhead cranes work more efficiently — and your operation more productive.

► **Industries:**

Iron and Steel, Manufacturing, Pulp and Paper

► **Key Applications:**

Trolley gears, hoist gears, traverse gears, open gears

(large tonnage cranes)

Sheaves and bearings

Electric motors

Wire ropes

► **Products:**

Mobil SHC 600 Series: 629–634

Mobil SHC Gear

Mobilith SHC 460

Mobil Polyrex EM

Mobilarma 797

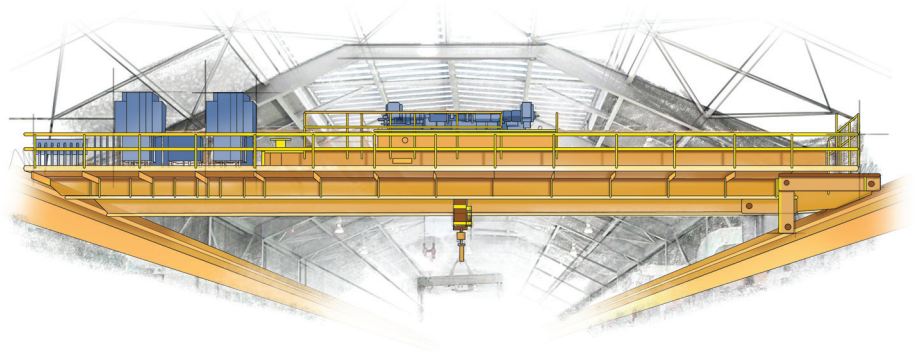

street view

► **Potential Mobil SHC Benefits:**

Extended oil drain intervals with monitoring/
reduced used oil

Reduced oil consumption/increased productivity

Reduced wear rates in heavily loaded applications/
increased equipment protection

Reduced unscheduled maintenance and downtime/
increased operator safety

► **Key Equipment Builder Preferential Endorsements:**

Please refer to the ExxonMobil Equipment Builders (EMEBs) guide for builder endorsements.

► **Proof of Performance:**

Customers using Mobil SHC lubricants and greases have reduced their annual operating costs considerably, increasing their productivity.

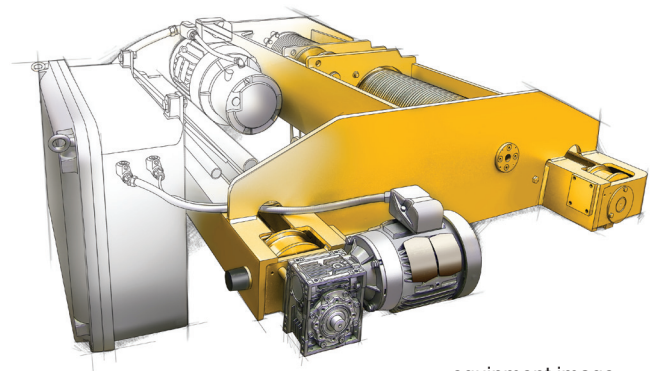

equipment image

For examples of how Mobil SHC has helped customers like you, contact your ExxonMobil representative.

mobilindustrial.com

Note: Schematic and product recommendations are intended as a general guide only. Products listed are typically the product series names. Please refer to equipment builder manual for final lubrication recommendations or consult your Mobil Industrial Lubricants team for additional products. NOT TO SCALE.

© 2012 Exxon Mobil Corporation

All trademarks used herein are trademarks or registered trademarks of Exxon Mobil Corporation or one of its subsidiaries unless indicated otherwise.