

Plastic calenders and extruders

Challenge: **High-temperature deposits and lubricant breakdown** can occur in heated calenders and extruder main screw radial and thrust bearings, which often operate above 130°C. These issues can lead to time-consuming, costly maintenance due to the need for precise calender roll alignment and extruder bearings that are hard to access.

Solution: **Protect your equipment with synthetic oils and greases** designed to resist high temperatures and oxidation for cleaner bearings and reduced wear. These lubricants are also designed to reduce friction, extend lube service intervals and enhance equipment reliability.

Compared to conventional lubricants, Mobil SHC™ lubricants can provide:



Safety

- Reduced maintenance risks for plant personnel



Environmental Care

- Reduced grease and oil consumption and related disposal



Productivity

- Fewer bearing failures, improving calender and extruder reliability
- Extended lubricant life
- Reduced maintenance costs and better use of plant labor

Industries

- Plastics processors — extrusions, sheet

Key applications

- Calender roll journal bearings (oil lubricated)
- Calender roll antifriction bearings (grease lubricated)
- Extruder main screw radial and thrust bearings (grease lubricated)

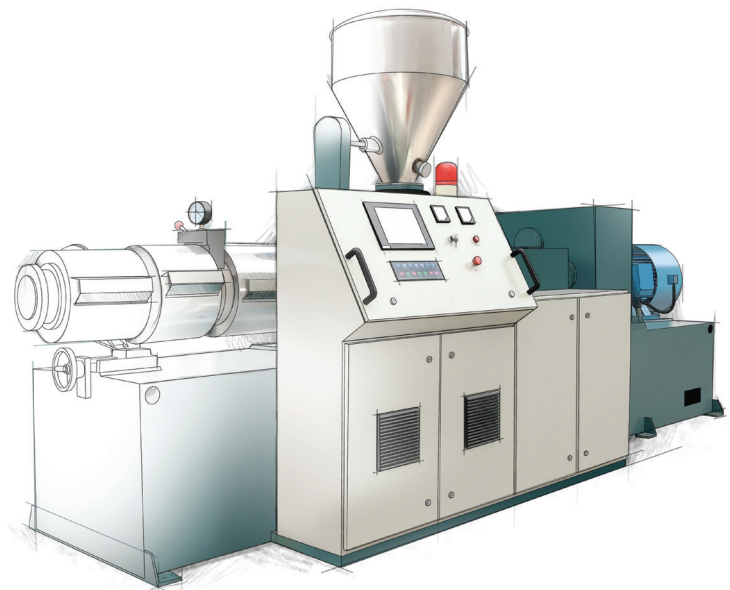

*Visit mobil.com/shc to learn how certain Mobil-branded lubricants may provide benefits to help minimize environmental impact. Actual benefits will depend upon product selected, operating conditions and applications.

Industrial
Lubricants



Plastic calenders and extruders

Products

- **Mobil SHC™ 600 Series oils***
 - Calender roll bearings
- **Mobil Glygoyle™ ISO Series oils**
 - Calender roll bearings
- **Mobil SHC Polyrex™ 462 synthetic grease**
 - Extruder main screw and thrust bearings

Key equipment builder approvals

Mobil SHC™ lubricants are endorsed by leading plastic processing equipment builders, including:

- Comerio Ercole S.p.A.
- Rodolfo Comerio S.r.l.

Visit mobil.com/industrial to search by equipment builder name for specific recommendations.

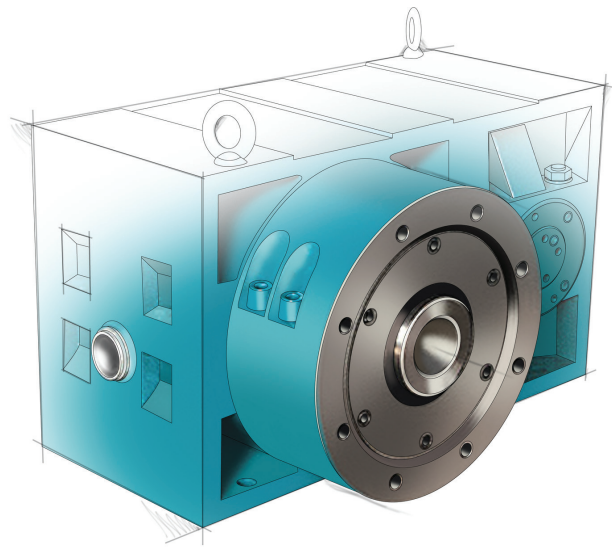

Proof of Performance

[Mobil SHC™ 636 helps Hebei Yuxing Plastic Co. Ltd. save US \\$133,000 annually on PVC calender Timken bearings](#)

[Mobil SHC™ 639 and Planned Engineering Services improve PVC film calender lubrication to reduce downtime and maintenance](#)

[Mobil SHC Polyrex™ 462 synthetic grease saves \\$12,000 annually on extrusion steam roller bearings](#)

Read the complete stories at mobil.com/shc, where you can explore other success stories and find out how Mobil SHC synthetic and Mobil Glygoyle™ ISO Series lubricants can energize your business.



*The energy efficiency design is a trademark of Exxon Mobil Corporation. Energy efficiency relates solely to the fluid performance when compared to conventional (mineral) reference oils of the same viscosity grade in circulating and gear applications. The technology used allows up to 3.6 percent efficiency compared to the reference when tested in a worm gearbox under controlled conditions. Efficiency improvements will vary based on operating conditions and application.

Note: Productivity Pointers are provided for the use of ExxonMobil and our authorized distributors. Schematics and product series recommendations are intended as a general guide. Please visit mobil.com/industrial for specific builder equipment recommendations.

© 2017 ExxonMobil. All trademarks used herein are trademarks or registered trademarks of Exxon Mobil Corporation or one of its subsidiaries.

mobil.com/shc